



ICM400

Three Phase Voltage Monitor with Reset Switch

Low cost line voltage protection for 3-phase motor systems

3-Position Reset Switch:

- MAN-MAN
- AUTO-AUTO
- AUTO-MAN

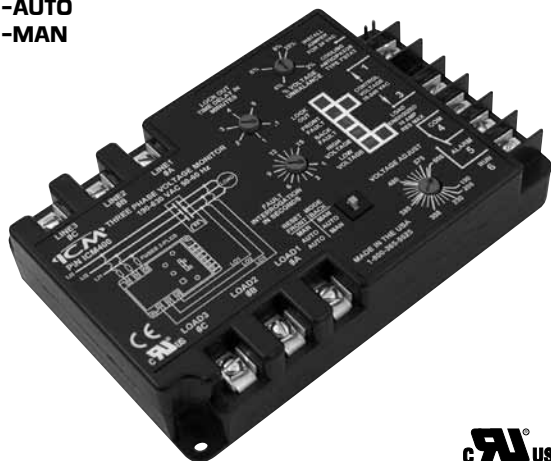

Installation, Operation & Application Guide

For more information on our complete range of American-made products – plus wiring diagrams, troubleshooting tips and more, visit us at www.icmcontrols.com



Specification

- Input**
- **Line Voltage:** Universal, 190-630 VAC
 - **Frequency:** 50-60 Hz
 - **Load Side Monitoring:** Optional
 - **Control Voltage:** 18-240 VAC
 - **Frequency:** 50-60 Hz
- Output**
- **Type:** Relay, SPDT
 - **Frequency:** 50-60 Hz
 - **Voltage Range:** 240VAC @ 10A max.
- Control Operating Temperature:**
- **Operating Temp:** -40°F to +167°F (-40°C to +75°C)
 - **Storage Temp:** -40°F to +185°F (-40°C to +80°C)
- Response Times:**
- **Phase Loss:** 2 seconds maximum
 - **Unbalance/High/Low:** Full selected trip delay period
- Mechanical:**
- **Mounting:** Surface mount using (2) #8 screws
 - **Terminations:** Screw terminals
 - **Weight:** 12 ounces (341 grams)
- Dimensions:** 6 1/2" L, 4 1/4" W, 1 3/8" H (16.5 cm. L, 10.8 cm. W, 3.5 cm. H)

Parameters

- Phase Unbalance Protection**
- **Voltage Unbalance:** 2-25% adjustable
- Over/Under Voltage Protection:**
- **Under Voltage:** -12% fixed, -6% for reset
 - **Over Voltage:** +12% fixed, +6% for reset
- Phase Loss Protection**
- **Phase Loss Condition:** Equals 25% of nominal for any given phase; system will shut down should this occur
- Lockout Delay Timer**
- **Input:** 18-240 VAC RMS
 - **Tolerance:** +/-20%
 - **Time Delay:** .1 to 5 minutes adjustable
 - **Bypass resistor (24 VAC only):** 1 kOhm @ 24 VAC
- Fault Interrogation Delay**
- **Time Delay:** 1-15 seconds adjustable
 - Provides a delay between fault detection and system shutdown - helps to eliminate nuisance trips or unnecessary shutdowns

Caution

Installation of the ICM400 shall be performed by trained technicians only. Adhere to all local and national electric codes. Disconnect all power to the system before making any connections.

Installation

- Using (2) #8 screws, mount the ICM400 in a cool, dry, easily accessible location in the control panel enclosure.
- Connect voltage as shown in Figure 1 (below). Leave existing line and load side connections intact on the contactor.
 - **Note:** Load side monitoring is optional (unit may be used to monitor line side only).
- Wire the contactor and control voltage monitoring as in Figures 2 and 3 (below).
 - **Note:** Load/line wire must be rated for 3-phase voltage rating, 20ga minimum.
- Upon application of power, the ICM400 will be online and will begin to monitor the system.

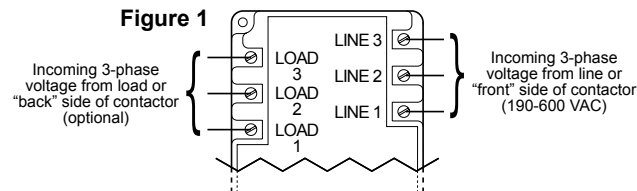

- Terminals 1 and 3 are the control signal input terminals
- There must be a voltage present on terminals 1 and 3 for the relay output terminals 4 and 6 to close; this voltage can be supplied from a thermostat, pressure switch, etc.
- When the voltage on these terminals is re-applied, the unit will not re-energize until the lockout delay (.1 to 5 minutes) time has elapsed

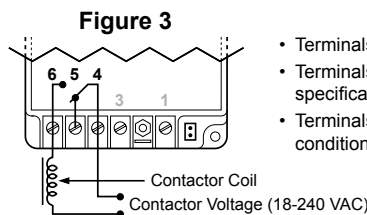
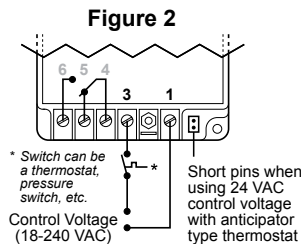

- Terminals 4 and 6 are "dry," normally open contacts
- Terminals 4 and 6 are closed when power is within specifications
- Terminals 4 and 6 open when there is a fault condition or loss of control signal

3-Position Reset Switch Operation

Choose from three, easy-to-select reset mode positions to best meet the needs of your system. The modes of operation for each position are described below.

Position 1: FULL MANUAL RESET (MAN-MAN)

Manual control reset required on both the front (line) and back (load) side of system. Used for highly critical loads. System will not reset until fault is corrected and manually reset by personnel. After a **front side fault** the unit will restart **only** if all of the following conditions are met:

- The lockout time is complete
- The **Reset Mode** switch is moved to the **AUTO-AUTO** position
- No fault condition exists

After a **back side fault** the unit will restart **only** if all of the following conditions are met:

- The lockout time is complete
- The Reset Mode switch is moved to the **AUTO-AUTO** position
- No fault condition exists

Position 2: FULL AUTOMATIC RESET (AUTO-AUTO)

Control automatically resets front (line) and back (load) sides of system. Used on less critical loads. Helps eliminate unnecessary service calls. After a **front or back side fault**, the unit will restart only if all of the following conditions are met:

- The lockout time is complete
- No fault condition exists

Position 3: AUTO FRONT/MANUAL BACK RESET (AUTO-MAN)

Automatic reset on the front (line) side only. Back (load) side requires manual reset. Typically used with reliable power supply. Back side faults require service evaluation and manual reset. After a **front side fault** the unit will restart **only** if all of the following conditions are met:

- The lockout time is complete
- No fault condition exists

After a **back side fault** the unit will restart **only** if all of the following conditions are met:

- The lockout time is complete
- The **Reset Mode** switch is moved to the **AUTO-AUTO** position
- No fault condition exists

ICM400 Setup

Voltage Adjust: Set knob to match 3-phase voltage of system

Fault Interrogation (in seconds):

Set to the amount of time for the **ICM400** to analyze a non-critical fault* before de-energizing the load **** Recommended:** 7 to 8 seconds

Lockout Time Delay (in minutes):

Set to the amount of time between the de-energizing of the load and the **ICM400** attempting to re-energize the load **** Recommended:** 4 minutes

% Voltage Unbalance:

Set to the amount of allowable voltage unbalance between the 3-phase lines **** Recommended:** 4 to 5%

* Non-critical faults are faults such as high/low voltage and phase un-balance. Critical faults are phase loss and phase reversal. When a critical fault is detected, the load is de-energized immediately.

** For best recommendations, consult manufacturer of motor/compressor.

ICM400 Wiring Diagrams

2-Pole Contactor

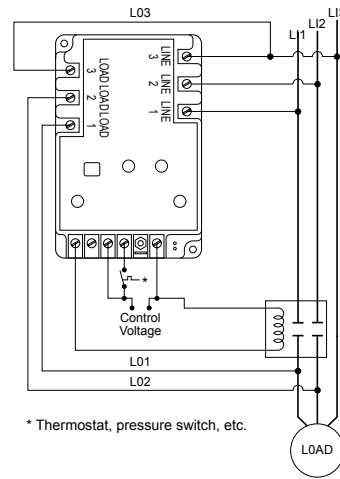

3-Pole Contactor

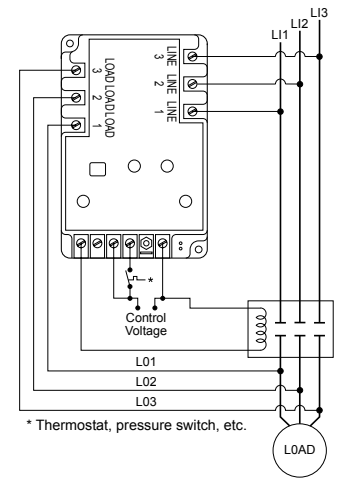

Typical System Diagram

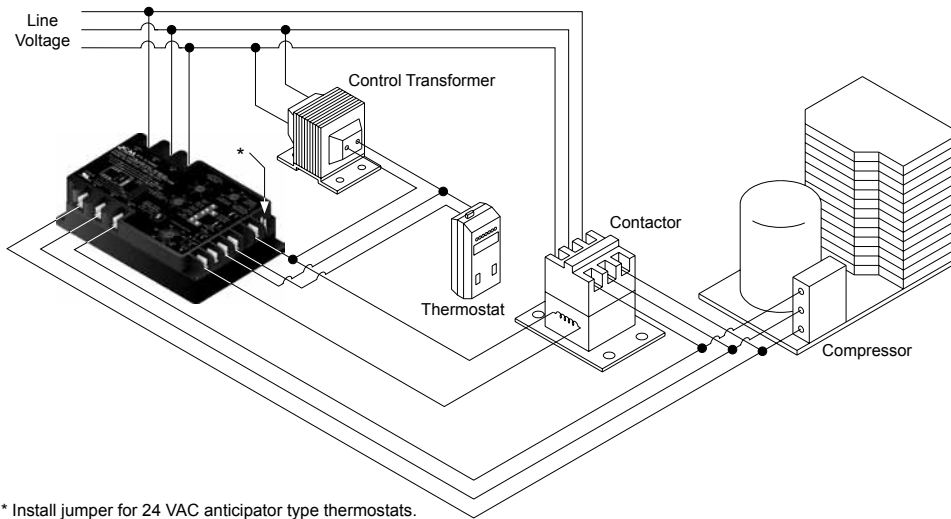

Troubleshooting

Problem	LED Status	Corrective Action
Load will not energize	All LEDs are OFF	Check incoming power and/or control voltage input
	Front fault LED ON	Slowly turn the Voltage Unbalance knob to maximum (25%): • If a fault condition continues, check for phase loss with voltmeter • If a fault condition still exists, reverse any two of the phases on the line side of the ICM400 *
	Front fault LED ON High or low LED ON	Turn the Voltage Adjust knob up or down very slowly until either High or Low voltage LED turns off
	Lockout LED ON	Turn Lockout Time Delay knob to .1 minutes; set reset switch to the AUTO-AUTO position
	Front fault LED ON after the load is OFF	Slowly adjust the Voltage Unbalance knob to a higher percentage
Load turns ON and OFF	Back fault LED ON	Check for voltage unbalance, phase loss or phase reversal on the load side of the ICM400
The load short-cycles when the thermostat is repeatedly opened and closed (thermostat bounce)	Lockout LED ON Back fault LED ON	Reconnect the control input as outlined in the (see Typical System Diagram)

* Only swap phases during initial setup, not after the **ICM400** has been in operation without errors.

** **Note:** After troubleshooting, reset all adjustment knobs and switches to motor/compressor manufacturer's recommendations.

ONE-YEAR LIMITED WARRANTY

The Seller warrants its products against defects in material or workmanship for a period of one (1) year from the date of manufacture. The liability of the Seller is limited, at its option, to repair, replace or issue a non-case credit for the purchase prices of the goods which are provided to be defective. The warranty and remedies set forth herein do not apply to any goods or parts thereof which have been subjected to misuse including any use or application in violation of the Seller's instructions, neglect, tampering, improper storage, incorrect installation or servicing not performed by the Seller. In order to permit the Seller to properly administer the warranty, the Buyer shall: 1) Notify the Seller promptly of any claim, submitting date code information or any other pertinent data as requested by the Seller. 2) Permit the Seller to inspect and test the product claimed to be defective. Items claimed to be defective and are determined by Seller to be non-defective are subject to a \$30.00 per hour inspection fee. This warranty constitutes the Seller's sole liability hereunder and is in lieu of any other warranty expressed, implied or statutory. Unless otherwise stated in writing, Seller makes no warranty that the goods depicted or described herein are fit for any particular purpose.



Patent No. 424,953

7313 William Barry Blvd., North Syracuse, NY 13212
(Toll Free) 800-365-5525 (Phone) 315-233-5266 (Fax) 315-233-5276

www.icmcontrols.com

LIAF054