

SDTA-02
Step Down Transformer Adapter

User's Manual



SDTA-02
Step Down Transformer Adapter

User Manual

PROPRIETARY INFORMATION

The information contained in this document is the property of **MULTITEL INC.** Except as specifically authorized in writing by **MULTITEL INC.**, the holder of this document shall:

1. Keep all information contained herein confidential and shall protect same in whole or in part from disclosure and dissemination to all third parties and
2. Use the same for operating and maintenance purposes only.

© 2001 Multitel Inc.
Printed in Canada 06/2001

Document name: UMSDTA02012
Issue: 1.2
Revised by: Eric Boivin
Date: 07/10/11

TABLE OF CONTENTS

CONTROL SHEET	4
CONTROL SHEET	4
1. GENERAL INFORMATION	5
1.1 DESCRIPTION	5
2. SUMMARY OF SPECIFICATIONS	7
2.1 ELECTRICAL	7
2.2 ENVIRONMENTAL	7
2.3 MECHANICAL	7
3. OPERATION	8
3.1 GENERAL	8
3.2 ANALOG CHANNEL SETUP	8
3.3 MULTITEL MONITORING SYSTEM CONFIGURATION SETUP	8
4. INSTALLATION	10
4.1 TOOLS AND EQUIPMENT	10
4.2 MOUNTING THE SYSTEM	10
4.3 WIRING AND CONNECTING	11
4.3.1 GENERAL INFORMATION	12
4.4 ALTERNATIVE VOLTAGE MEASUREMENTS	12
5. MAINTENANCE	16
5.1 CALIBRATION	16
5.2 TROUBLESHOOTING	16
5.2.1 General	16

FIGURES:

Figure 1 - Physical Aspect	6
Figure 2 - Wall Mount Installation of the SDTA-02	11
Figure 3 - AC Current and Voltage Measurements	13
Figure 4 - Connector Definitions	14

TABLES:

Table 1 – SDTA-02 Models and Part Numbers	5
Table 2 – Current and voltage data for analog channel configuration	8
Table 3 – SDTA-02 Setup	9
Table 4 – Diagnosis Path for Troubleshooting	17

CONTROL SHEET

<i>ISSUE</i>	<i>DATE</i>	<i>DESCRIPTION</i>	<i>ORIGINATOR</i>
1.0	93/06/25	First English issue.	Pierre Poulin
1.01	94/10/12	-	-
1.02	97/05/08	Minor modifications and new formatting.	François Dionne
1.1	00/06/16	New certification information for CSA-c and CSA-US	Gilles Belleau
1.12	01/09	Review	Johanne Lavallée Gilles Belleau
1.2	10/07/11	Changer adresse	E. Boivin

1. GENERAL INFORMATION

1.1 DESCRIPTION

The SDTA-02 is an interface accessory that converts AC voltage and current signals into an AC signal compatible with MULTITEL monitoring systems.

The following list shows the eight possible configurations available for the SDTA-02 interface.

Table 1 – SDTA-02 Models and Part Numbers

DESCRIPTION	MULTITEL PART #
SDTA-02, 240 VAC 3 phases	M-4173*
SDTA-02, 600 VAC 3 phases	M-4178*

*These models are CSA and CSA “US” approved.

For current measurement (0-1000A), current transformers are used to provide the 0-5 Amp output signal required by the current input interface.

For voltage measurements (0 to 240 VAC and 0 to 600 VAC), three (3) voltage input interfaces are provided, each with a 2-wire input connection.

Figure 1 - Physical Aspect



2. SUMMARY OF SPECIFICATIONS

2.1 ELECTRICAL

Current consumption	150 mA / phase maximum
Current input range	0-5 A AC
Input impedance	
Voltmeter	240 V : 2400 Ω 600 V : 6000 Ω
Ammeter	0.2 Ω
Output signal	
Voltmeter	17 VAC, 2 nominal inputs (max. 28 VAC)
Ammeter	500 mVAC

2.2 ENVIRONMENTAL

Temperature	
Operation	0°C to 50°C (32°F to 122°F)
Storage	-40°C to 70°C (-40°F to 158°F)
Humidity	
Operation	0 to 90%, non-condensing
Storage	0 to 95%, relative humidity

2.3 MECHANICAL

Height	43 cm (17")
Width	25 cm (10")
Depth	8 cm (3")
Weight	3.2 kg (7 lbs)

3. OPERATION

3.1 GENERAL

The SDTA-02 is designed to transform high-AC currents and voltages into a current or voltage scale compatible with analog channels on MULTITEL's monitoring systems, such as the RPM-1000/C, the MXP2 188 and the MIRADOR.

3.2 ANALOG CHANNEL SETUP

The SDTA-02 will send its measurements to several analog channels on your MULTITEL monitoring system. In order to operate properly, those analog-input channels need to be programmed with the proper scaling factor according to the AC voltage or AC current input range (see Table 2). Please refer to the user's manual of your MULTITEL monitoring system for a complete description of steps to follow in order to configure it accordingly.

Table 2 – Current and voltage data for analog channel configuration

INPUT RANGE	SCALE	INPUT SOURCE
0-240 VAC	565	Voltage
0-600 VAC	1400	Voltage

3.3 MULTITEL MONITORING SYSTEM CONFIGURATION SETUP

The SDTA-02 has been set in the factory according to your needs. However, you should check that setting is correct in order to avoid erratic readings (see the following table).

Table 3 – SDTA-02 Setup

PHASE	JUMPER	MXP2/MIRADOR	RPM 1000/C
Phase A	JP5	OFF	ON
	JP6	ON	OFF
	JP9	ON	OFF
Phase B	JP3	OFF	ON
	JP4	ON	OFF
	JP8	ON	OFF
Phase C	JP1	OFF	ON
	JP2	ON	OFF
	JP7	ON	OFF

4. INSTALLATION

4.1 TOOLS AND EQUIPMENT

The following tools and test equipment are recommended:

- Safety glasses
- Crimping tools, Amp model: 90123-2 (Pliers and a soldering iron may also be used).
- Pliers, tie-wraps, twin or friction tape
- Tarpaulin, canvas
- RMS multimeter with clamp-on meter
- Bx cable 14/2#
- Belden cable #9305 or #20 AWG stranded

NOTE:

Unpack and verify with the "Material list" that all the material is received and in good condition.

4.2 MOUNTING THE SYSTEM

- Install the SDTA-02 as close as possible to the AC voltage or current source to be measured, in order to minimize risk associated with the transmission of AC voltage.
- Install the SDTA-02 on a flat wall surface.
- Do not install the SDTA-02 in the electrical box.

NOTE:

Protect the equipment from liquids.

Figure 2 - Wall Mount Installation of the SDTA-02

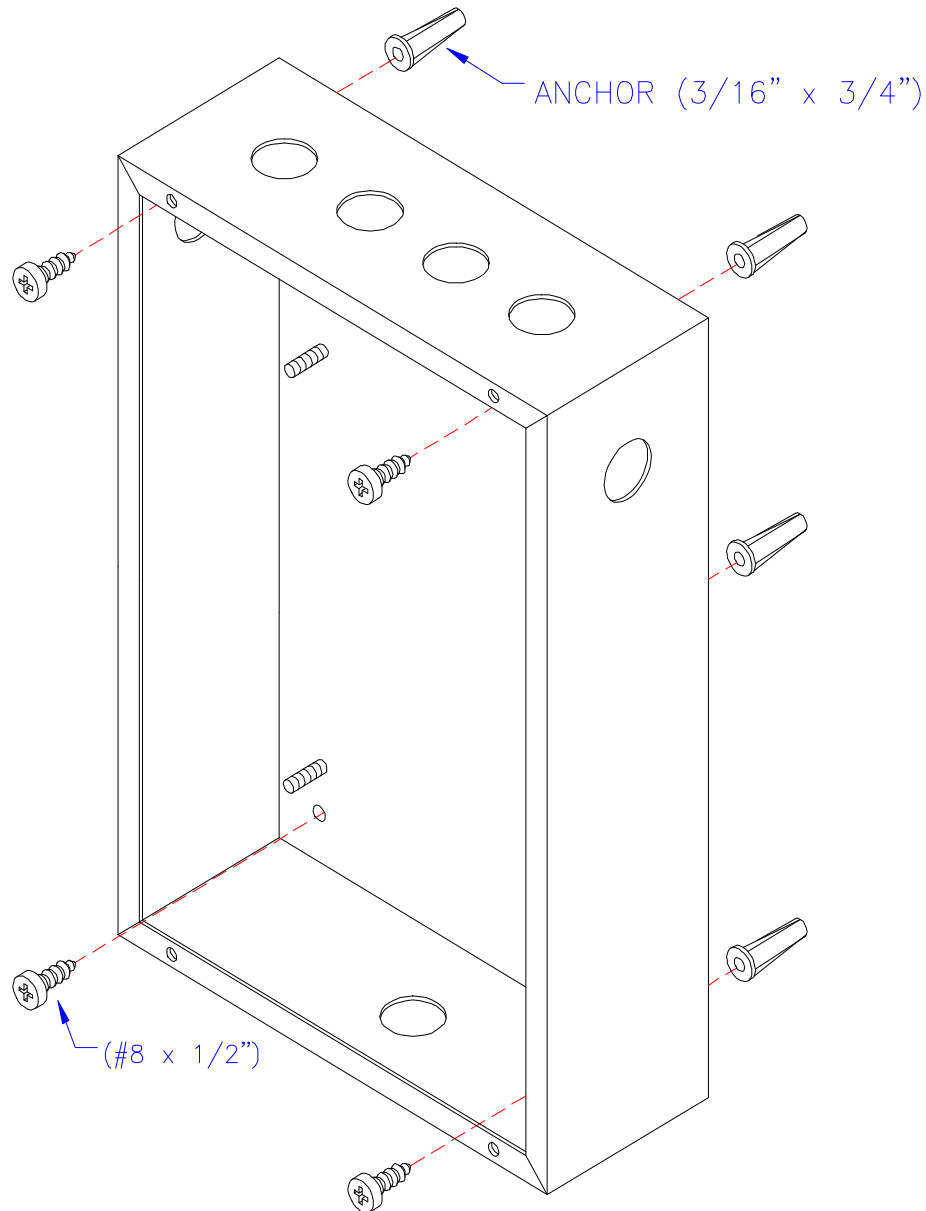

4.3 WIRING AND CONNECTING

IMPORTANT:

This Cabling and connecting section provides the general installation procedures and describes how to interconnect and put into service a SDTA-02

CAUTION: MAINTAIN PERMANENT SEPARATION BETWEEN THE PRIMARY LINE WIRING AND SECONDARY CIRCUITS.

4.3.1 GENERAL INFORMATION

- Read the following instructions **before beginning the actual installation**. It is important to have a global view of the installation in order to install the equipment properly.
- For more detail on the operation of MULTITEL monitoring systems, please refer to their user's manuals.
- Special precautions must be taken when handling current transformers (CTs). Follow the manufacturer's instruction supplied with the CTs.
- Make sure that polarity dots on CTs is respected.

4.4 ALERNATIVE VOLTAGE MEASUREMENTS

Connect each breaker output (max. 15 Amp) for each phase (A, B, and C) to its corresponding step down transformer input located in the SDTA-02 box using #14 AWG wire.

NOTE:

Each step down transformer output is preconnected to the SDTA-02 circuit board.

- Connect the frame ground to the ground lug of the SDTA-02 located on top of the circuit board using #14 AWG wire.
- Connect the corresponding pins of the J1 and J2 connectors on the MULTITEL monitoring system analog channel inputs using #24 AWG wire or bigger.

Figure 3 - AC Current and Voltage Measurements

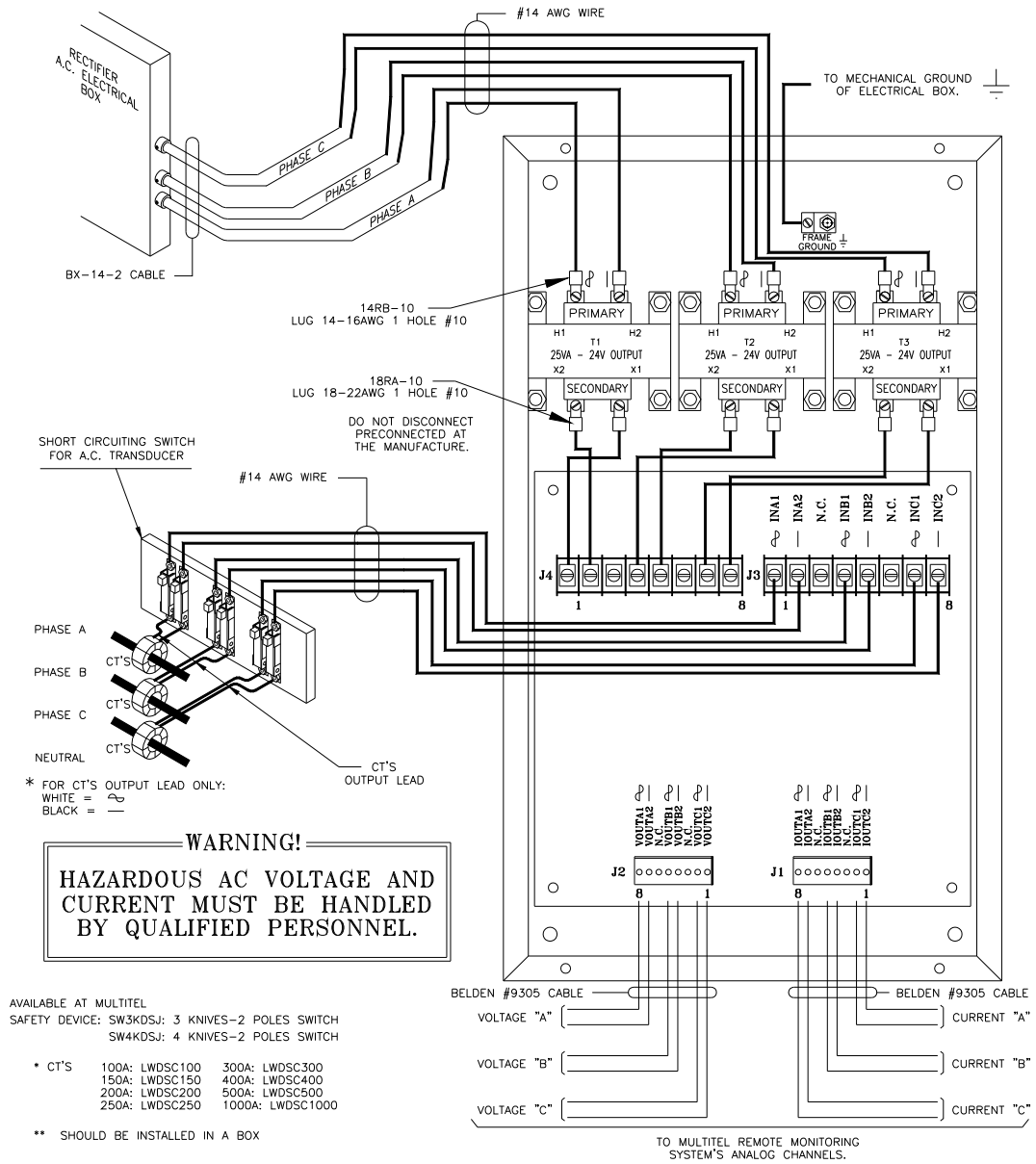

Figure 4 - Connector Definitions**J1 DEFINITION**

PIN	NAME	USE	TYPE	PIN	NAME	USE	TYPE
1	IOUTC2	Ammeter phase C common output lead	OUT	5	IOUTB1	Ammeter phase B output lead	OUT
2	IOUTC1	Ammeter phase C output lead	OUT	6	N.C.	Not connected	N.A.
3	N.C.	Not connected	N.A.	7	IOUTA2	Ammeter phase A common output lead	OUT
4	IOUTB2	Ammeter phase B common output lead	OUT	8	IOUTA1	Ammeter phase A output lead	OUT

J2 DEFINITION

PIN	NAME	USE	TYPE	PIN	NAME	USE	TYPE
1	VOUTC2	Voltmeter phase C common output lead	OUT	5	VOUTB1	Voltmeter phase B output lead	OUT
2	VOUTC1	Voltmeter phase C output lead	OUT	6	N.C.	Not connected	N.A.
3	N.C.	Not connected	N.A.	7	VOUTA2	Voltmeter phase A common output lead	OUT
4	VOUTB2	Voltmeter phase B common output lead	OUT	8	VOUTA1	Voltmeter phase A output lead	OUT

J3 DEFINITION

PIN	NAME	USE	TYPE	PIN	NAME	USE	TYPE
1	IINA1	Phase A xducer's input lead	IN	5	IINB2	Phase B common input lead	IN
2	IINA2	Phase A common input lead	IN	6	N.C.	Not connected	N.A.
3	N.C.	Not connected	N.A.	7	IINC1	Phase C xducer's input lead	IN
4	IINB1	Phase B xducer's input lead	IN	8	IINC2	Phase C common input lead	IN

J4 DEFINITION

<i>PIN</i>	<i>NAME</i>	<i>USE</i>	<i>TYPE</i>	<i>PIN</i>	<i>NAME</i>	<i>USE</i>	<i>TYPE</i>
1	VINA1	Phase A VAC input lead	IN	5	VINB2	Phase B VAC common input lead	IN
2	VINA2	Phase A VAC common input lead	IN	6	N.C.	Non connected	N.A.
3	N.C.	Not connected	N.A.	7	VINC1	Phase C VAC input lead	IN
4	VINB1	Phase B VAC input lead	IN	8	VINC2	Phase C VAC common lead	IN

5. MAINTENANCE

5.1 CALIBRATION

The SDTA-02 does not need periodic maintenance. However, if the output values provided by the SDTA-02 are erratic (after verification), the MULTITEL power monitoring system may be programmed to compensate the differential in measurement.

Tools and/or equipment required for calibration:

- AC voltage -on RMS multimeter
- Terminal or portable computer to communicate with MULTITEL monitoring system (emulation of VT-100, ANSI in some cases).

Potentiometer attribution of SDTA-02

P4 = AC VOLTAGE PHASE C

P5 = AC VOLTAGE PHASE B

P6 = AC VOLTAGE PHASE A

Follow the steps in order to calibrate the erratic measurement:

1. Configure the MULTITEL monitoring system's analog channel according to specifications.
2. Read the source value with an RMS multimeter or RMS clamp-on meter.
3. Adjust the corresponding potentiometer until the value displayed on the MULTITEL monitoring system equals the value read with the RMS multimeter or RMS clamp-on meter.
4. Verify the reading and repeat step 2, 3 and 4 until both readings are the same.

5.2 TROUBLESHOOTING

5.2.1 General

This section lists some helpful hints on how to analyze problems that may occur. When the problem is still not identified after reading this section, please contact a Customer Service representative at 418-847-2255 or support@multitel.com.

NOTE:

Before returning any defective unit, please make arrangements with your nearest Multitel customer service representative.

Table 4 – Diagnosis Path for Troubleshooting

<i>SYMPTOM</i>	<i>POSSIBLE CAUSE</i>
No reading, the monitoring system displays 0 volts.	1) The MULTITEL monitoring system's analog channel is disabled (refer to the user manual for the corresponding MULTITEL monitoring system).
	2) The analog channel of your MULTITEL monitoring system is not the correct type. Digital signal processing must be true RMS.
	3) There is no AC voltage or AC current present at the SDTA-02 inputs.
	4) Verify jumper settings (see Table 2).
	5) The wiring is compliant with specifications in the SDTA-02 connector definition .
	6) If all of these possible causes are not true, your SDTA-02 may be defective (refer to Multitel's Customer Service).
The reading is erratic.	1) The calibration is not adequate; refer to the calibration section in this manual.
	2) Verify that each input is in phase.
	3) The scaling is not adequate.

If the SDTA-02 is defective in any way, please contact our customer service agent at 1-418-847-2255, ext. 291 who will then issue you an RMA number so that you may return the defective material. Please insure that the RMA number is clearly marked on the package including our full address.

Our shipping address is:

**MULTITEL Inc.
2500 Jean-Perrin Street
Québec, Qc.
G2C 1X1**